



# Global Web Finishing Introduces Our New **- Patent Pending -**

## UNI VERSAL COATER

Absolutely The Most Capable Portable *UV Coater EVER* Designed for the Web  
Offset and Digital Web Printing Industries

- *Unsurpassed Print Quality of ANY Liquid UV Cured Coating Material on Virtually ANY Web surface Via Quick Change Coating Supply Cylinder*
- *In-The-Round Gapless Plate Cylinder With GWF's **Patent Pending** "DMR" Print Registration Technique Prints Solids to Screens and Matches ANY Fixed or Variable Repeat Cutoff Length in the House!*
- *On Board High Intensity UV Curing System with Quick Hinge Positioning for Quick Cure or Extended Flow Out Includes Integrated Chill Drum Roller*
- *Produce Intricate Image Reproduction and Exact Coating Film Control for **DM Advertising/ Specialty -Mag/Cat Covers-Security Printing- Inkjet/Digital Protection and Enhancement***

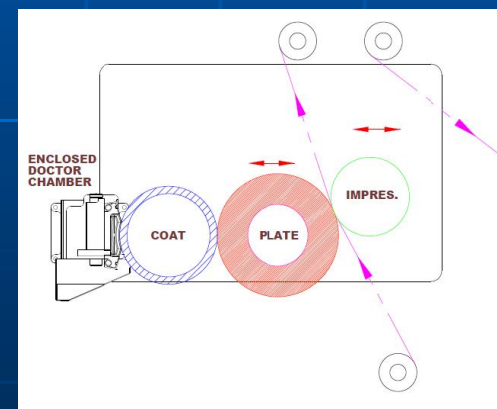
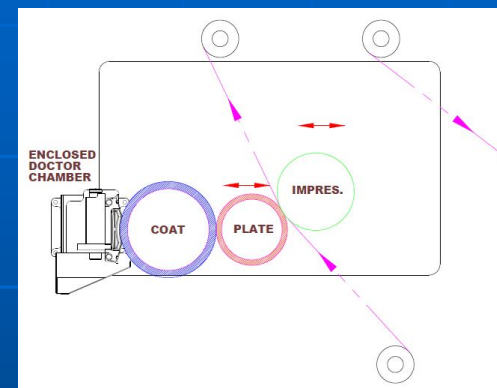



## UNI VERSAL COATER

- **Gloss Varnish** at perfectly desired application rates based on paper surfaces. Primary applications for visual enhancement; longevity/ durability; protecting inkjet addresses; marking protection and image enhancement for 4c inkjet applications.
- **Matte Varnish** at perfectly desired application rates based on paper surfaces to add visual enhancement; longevity/durability and subtle texture to smooth web substrate surfaces.
- **Silicone Release Coatings** in minimized application rates to seal substrate surface prior to secondary coating applications. Common apps include, paper sealant for stickers/stamps/labels; undercoating for scratch off coatings.
- **Scratch-Off Coatings** applied at precise rates so message cover is ideal without dangers of show through or over application resulting in poor curing or offsetting. Professional results worthy of high end applications such as lottery, sweepstakes when used in conjunction with silicone release and inkjet overprint.
- **Glitter, Pearl Effect and Glow-in-the-Dark Coatings** carrying metallic or other effect solids for extraordinary image enhancement/effect. Glitter enhanced varnishes are perfect for specialty promotion and security projects. Pearl appearance overprint coatings enhance 4c process print images without adding additional ink colors or lithographic print units. Glow-in-the-Dark coatings are ideal for specialty promotions as well as a hidden security feature.



## UNI VERSAL COATER

- ***Pseudo "Emboss" Coatings*** create a fantastic appeal and second look characteristic for advertisers. Everything from textures of leather and fabric to the ability to add raised lettering for richness enhancement or Braille effects. Desired finished heights common at 1-2mils.
- ***Pseudo "Sheet Magnet" Coatings*** offer one of the most effective marketing promotions ever in the form of non permanent "fridge" magnets. Material needs to finish on substrate in the range of 3-4mils.
- ***Thermo Chromatic Coatings*** offer very specialized and highly value added and quality user interaction. Technical apps are numerous and varied.
- ***Magnetic Strips for Embedded Card Information*** allows three lines of dynamic information for lower to mid level security and temporary usage applications. Information can be encoded on the run at web speeds immediately after magnetic strip is applied and cured.

*- Patent Pending -*

